

SCHEIBENVERSTÄRKUNG

Windshield stabilizer | Stabilizzator per Parabrezza | Stabilisateur de Pare-brise | Estabilizador de Parabrisas

ArtNr.: 90155-002

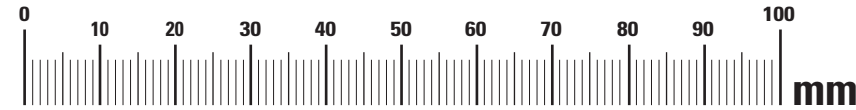

#	BEZEICHNUNG / DESCRIPTION	DE EN FR	Die Farben der Abbildungen dienen nur der Veranschaulichung. The colors are for illustrating purposes only. Les couleurs utilisées sont à titre indicatif seulement.	DIN	ISO	MENGE QUANTITY
1	Basishalter / base bracketed					1
2	Scheibehalter / windshield bracketed					1
3	Sicherungsscheibe / lock washer			6799		1
4	Bolzen / pin					1
5	Sechskantmutter / hexagon nut M6			985	10511	1
6	Rändelschraube / knurled screw M6					1
7	Hülse / sleeve 5mm					1
8	Linsenkopfschraube / lens head screw M5x25					1
9	Hülse / sleeve 3mm					2
10	Linsenflanschschraube / lens head screw M6x25			7381	7381	2
11	Hülse / sleeve 20mm					1

LEGENDE/KEY/FILE LÉGENDE

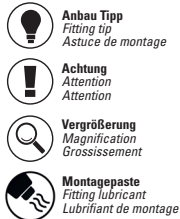

Die Hülse (11) dient nur dem Einpressen des original Halters auf den Bolzen. (Siehe Bild 8)
The sleeve (11) serves only to press the original bracketed onto the pin. (See picture 8)
La douille (11) sert uniquement à appuyer le support original sur le boulon. (Voir photo 8)

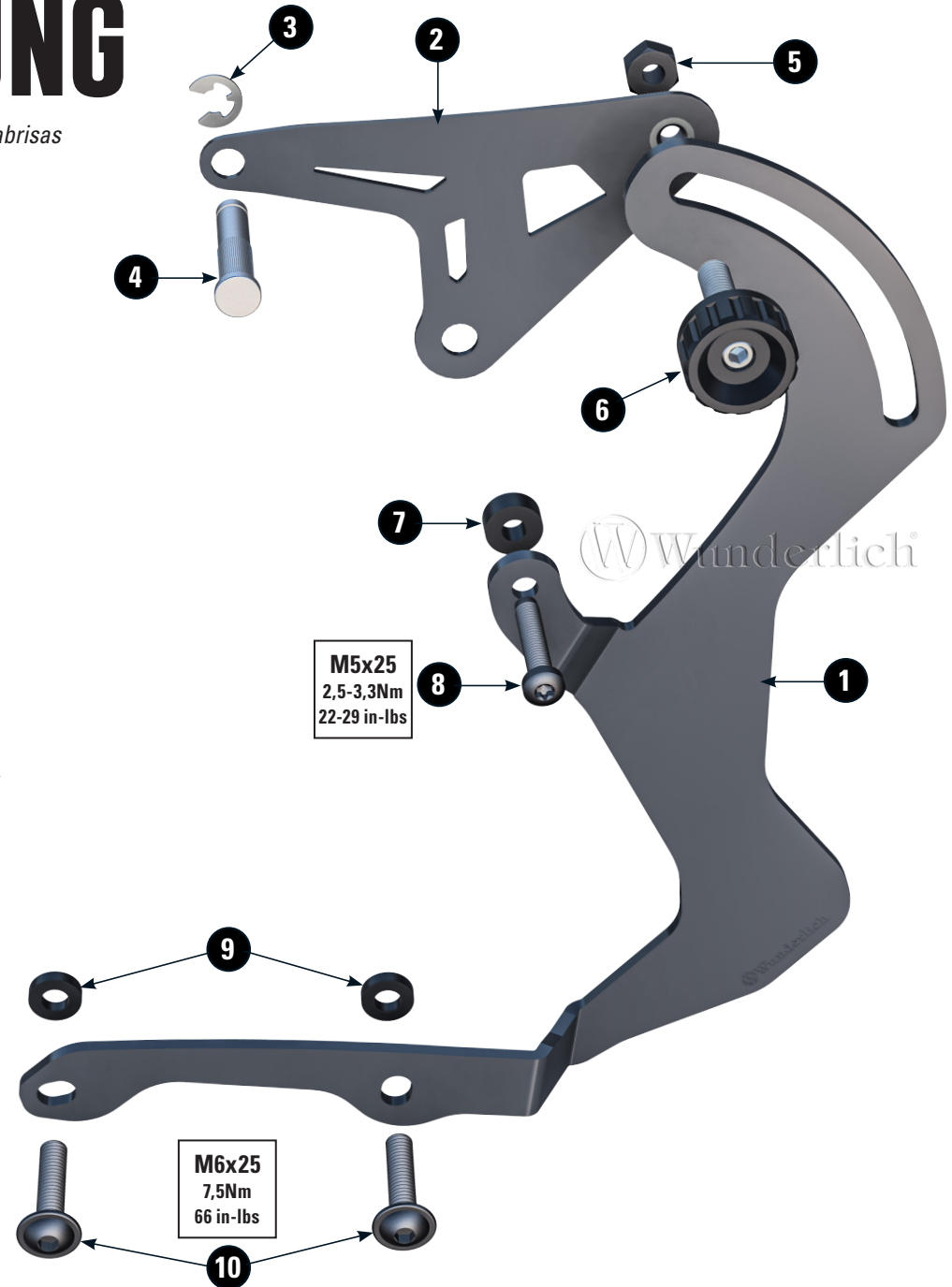
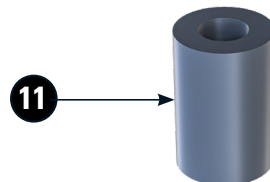

M5x25
2,5-3,3Nm
22-29 in-lbs

M6x25
7,5Nm
66 in-lbs

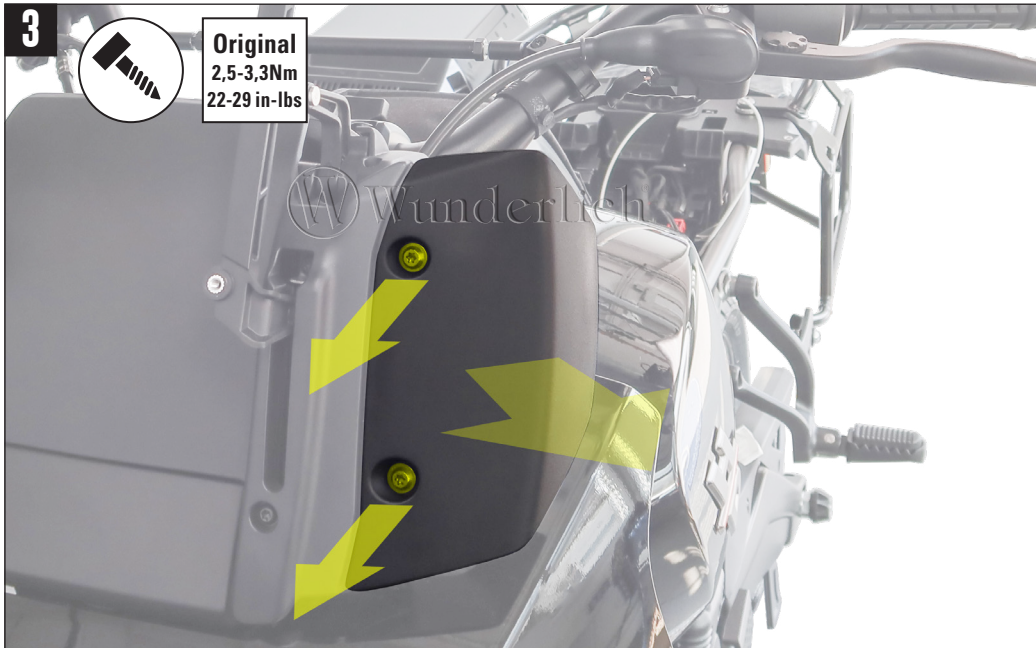
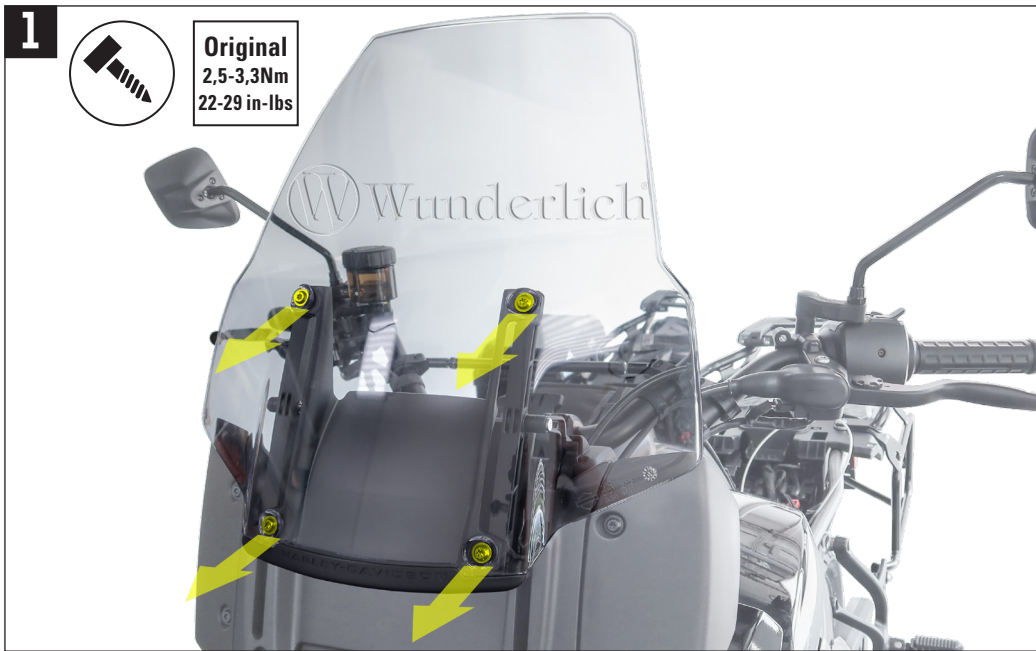

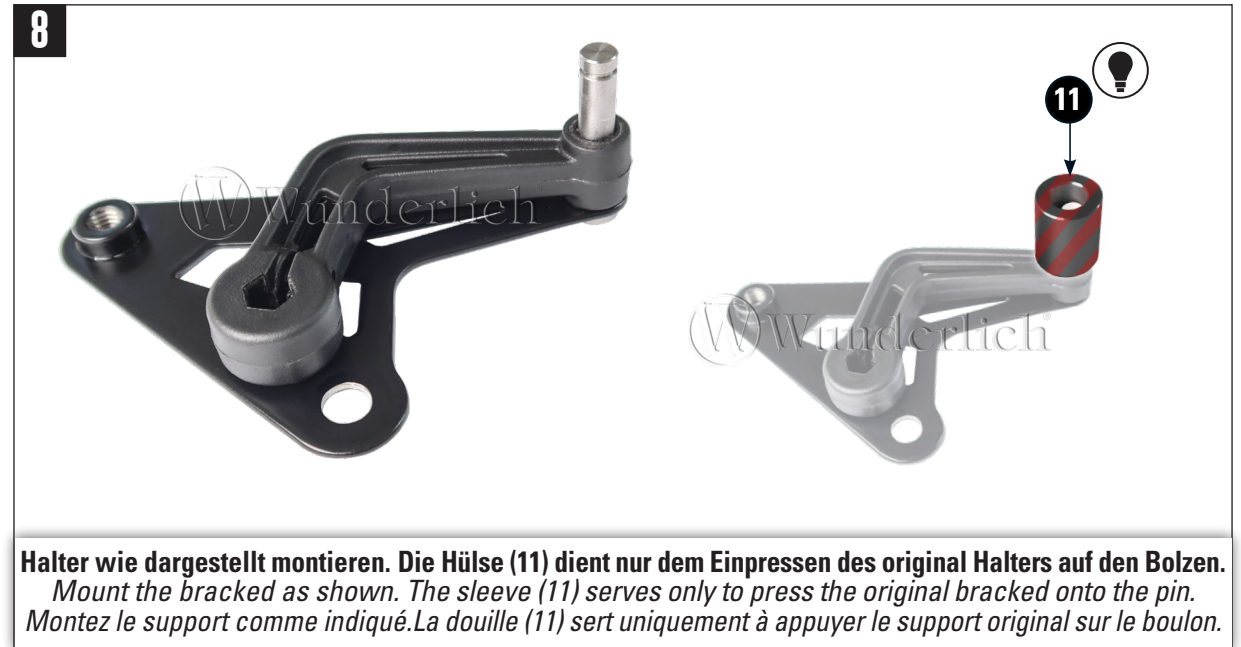

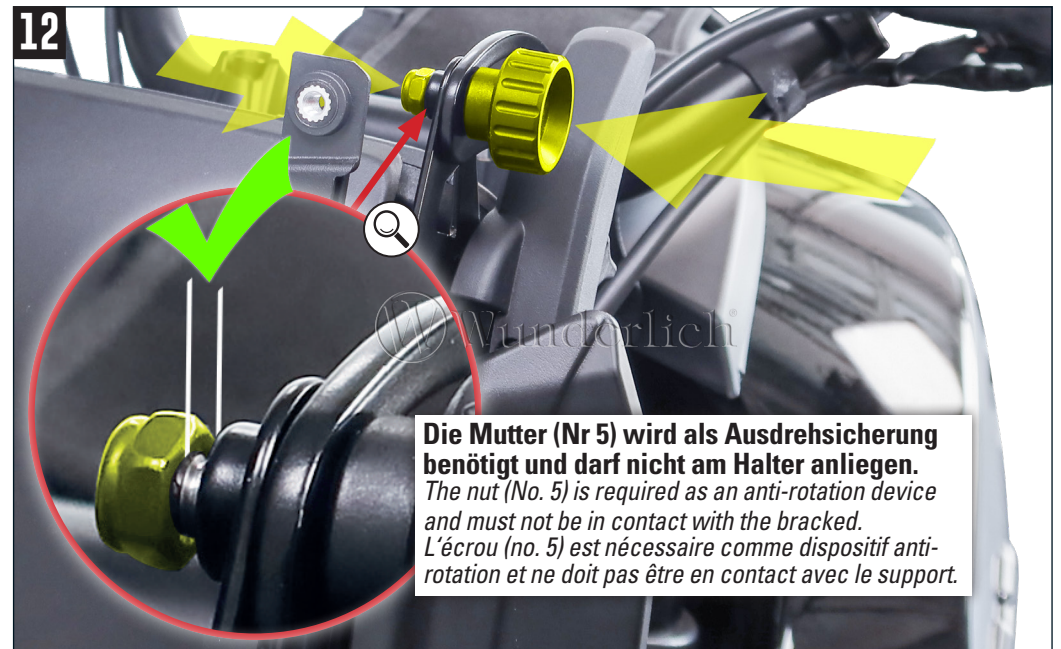
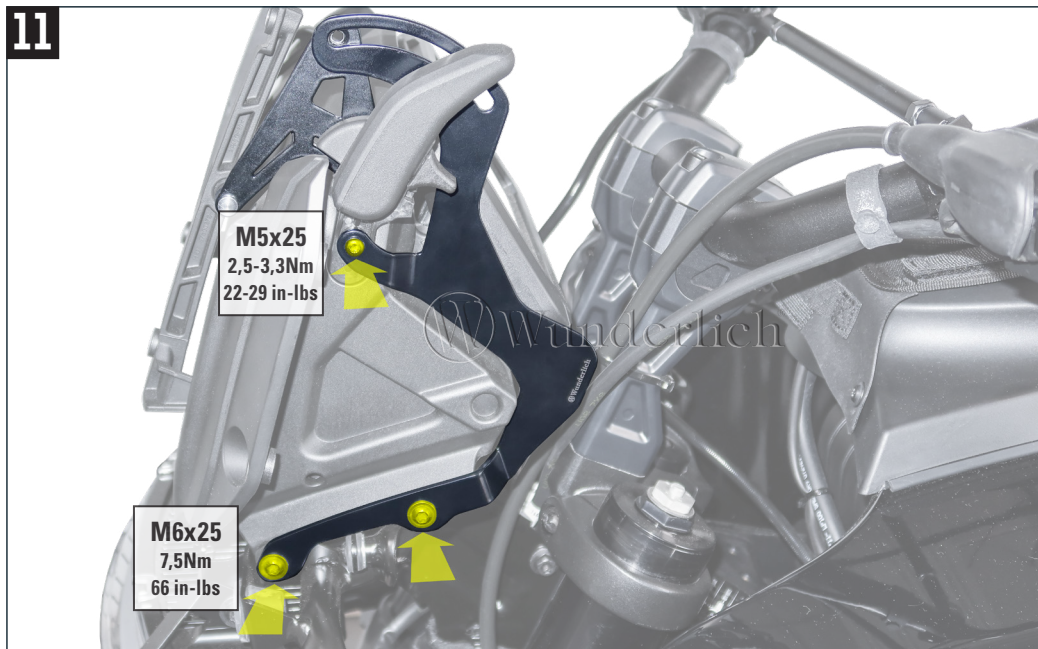
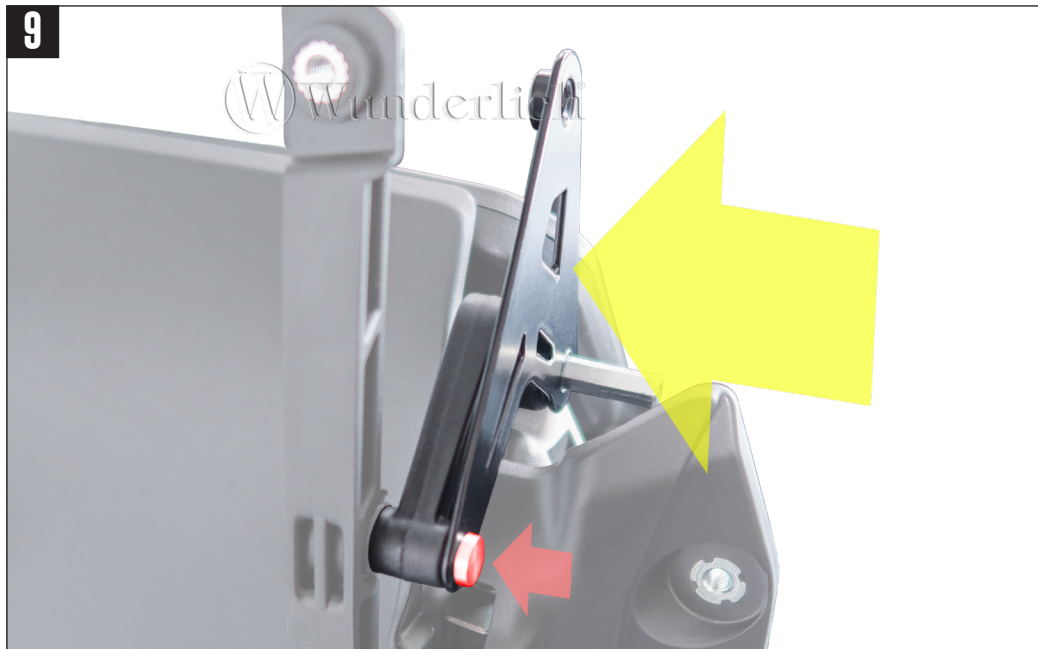

13

Zusammenbau in umgekehrter Reihenfolge.
Reassemble in reverse order.
Remontez dans l'ordre inverse.

