

# BREMSPUMPENSCHUTZ

Brake cylinder guard | Protection de pompe de frein | Protección para bomba de freno | Protezione per pompe freno

Art.-Nr: 71010-002

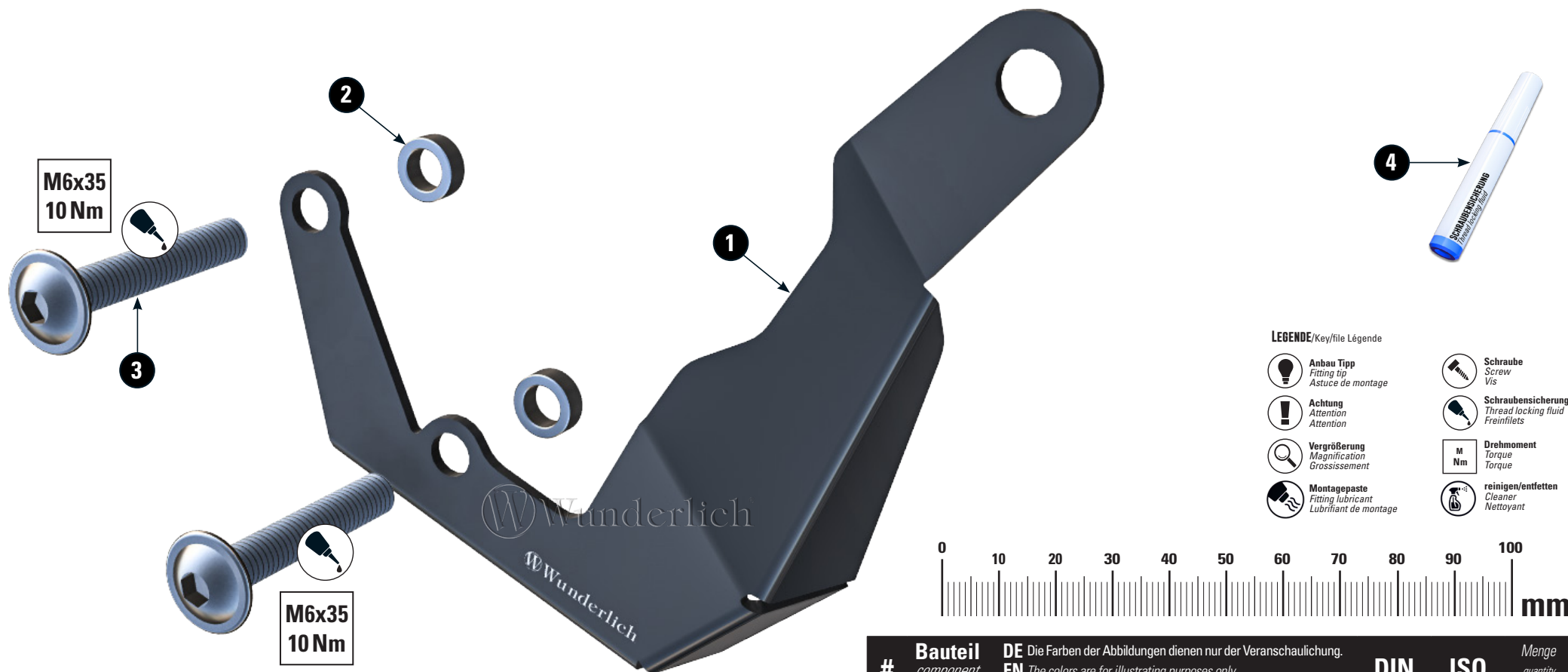

### LEGENDE/Key/file Légende

- Anbau Tipp**  
Fitting tip  
Astuce de montage
- Achtung**  
Attention  
Attention
- Vergrößerung**  
Magnification  
Grossissement
- Montagepaste**  
Fitting lubricant  
Lubrifiant de montage
- Schraube**  
Screw  
Vis
- Schraubensicherung**  
Thread locking fluid  
Freinfilets
- Drehmoment**  
Torque  
Torque
- reinigen/entfetten**  
Cleaner  
Nettoyant

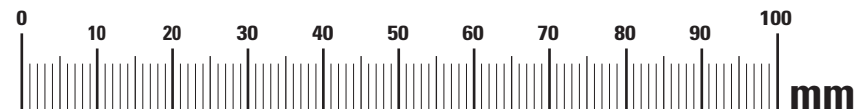

#	Bauteil component composant	DE Die Farben der Abbildungen dienen nur der Veranschaulichung. EN The colors are for illustrating purposes only. FR Les couleurs utilisées sont à titre indicatif seulement.	DIN	ISO	Menge quantity quantité
1	Bremspumpenschutz / Brake cylinder guard				1
2	Linsenflanschschraube / Lens head screw M6x35		7381	7381	2
3	Hülse / Sleeve 4mm				2
4	Schraubensicherung / Thread locking fluid				1



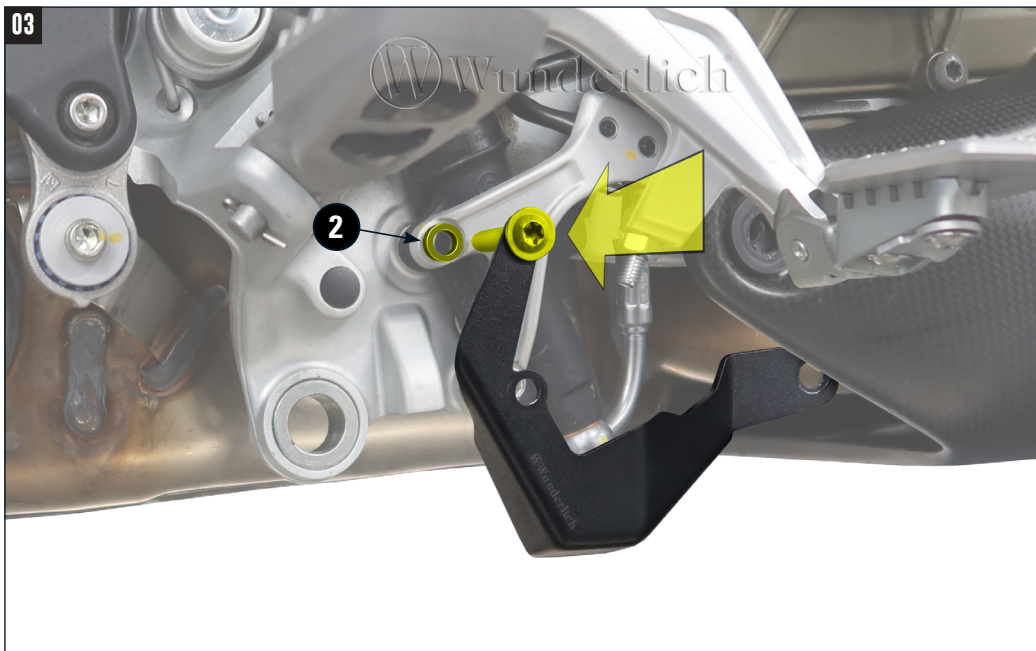
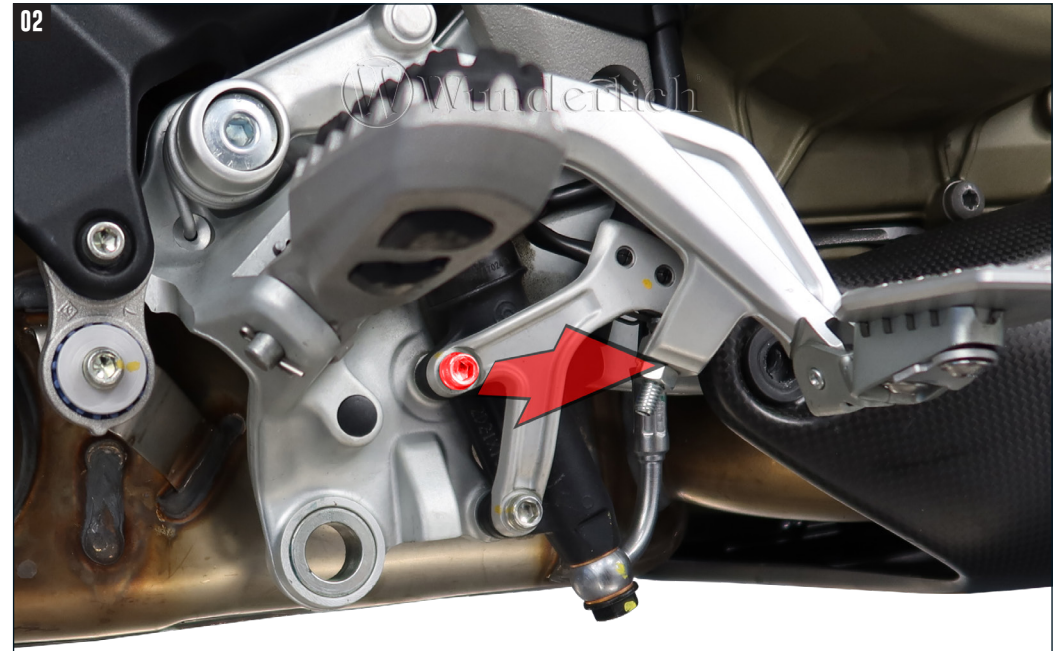



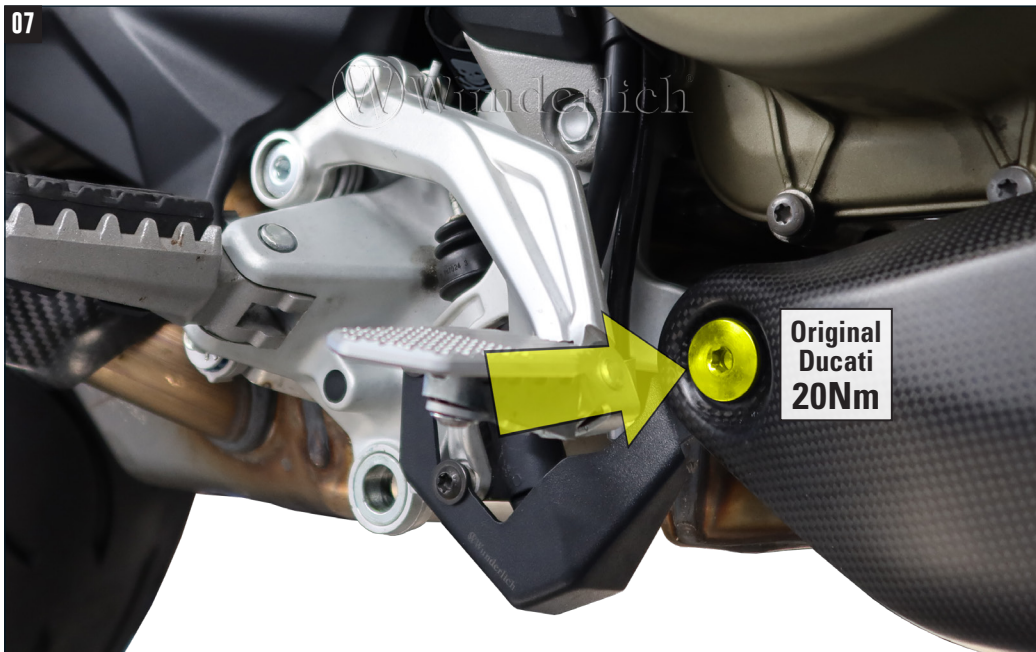
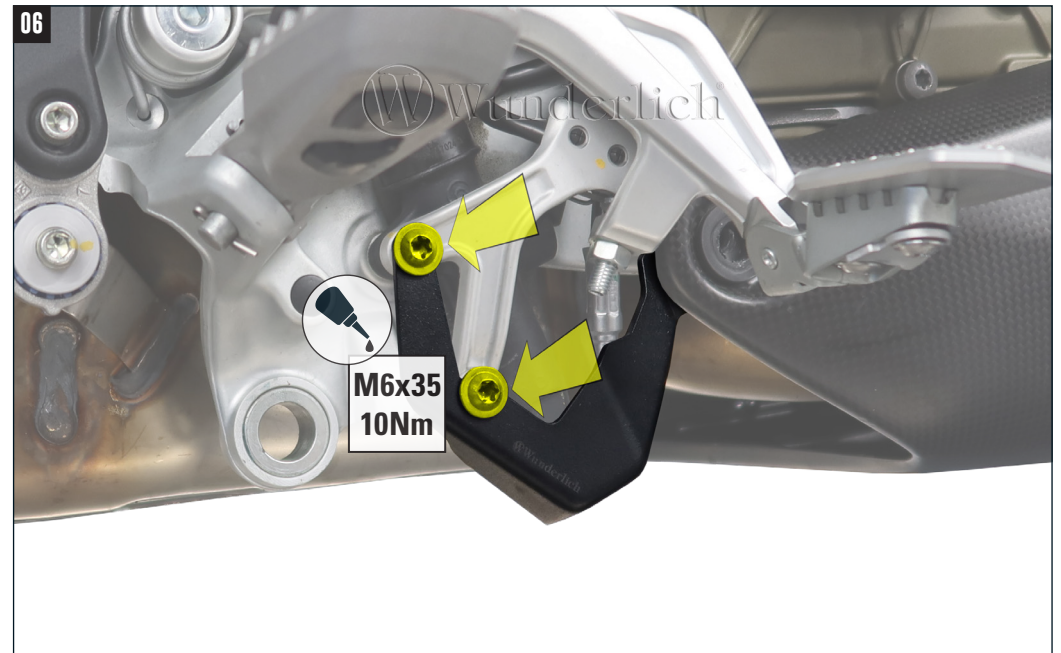

**Achten Sie darauf, den Bremslichtschalter nicht zu beschädigen und prüfen Sie nach der Montage seine Funktion.**

*Make sure not to damage the brake light switch and check its function after assembly.*

*Veillez à ne pas endommager le commutateur du feu de freinage et vérifiez son fonctionnement après l'assemblage.*