

MONTAGESATZ ZUSATZSCHEINWERFER

Additional headlight mounting kit | Kit de montage de phare supplémentaire | Kit de montaje de faro adicional | Kit di montaggio fero aggiuntivo

Art.-Nr: **28342-202**

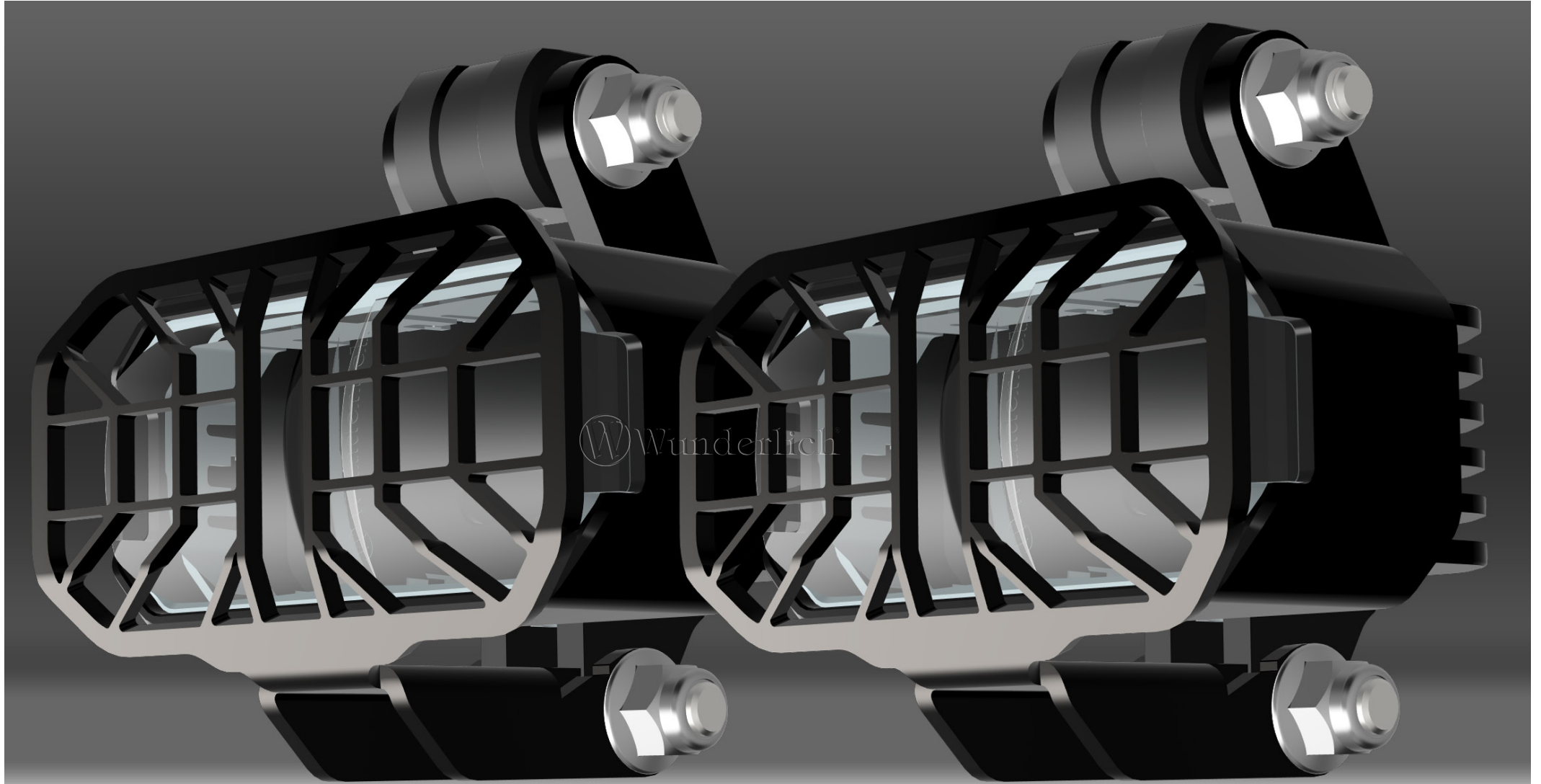

Wunderlich

18.12.2025





M6x35
8Nm

1



3



M5x16
2Nm

2



4

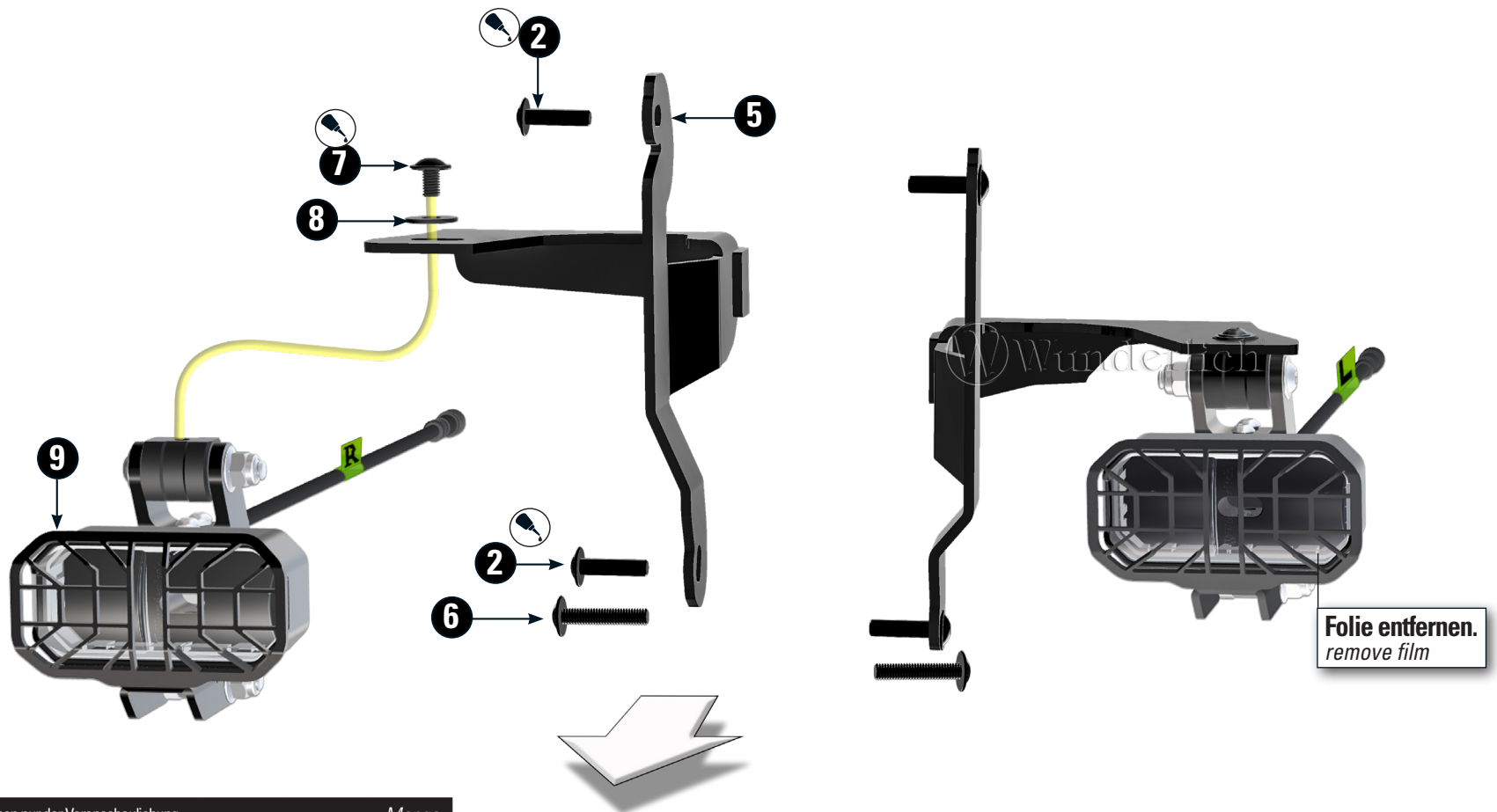

#	Bauteil component composant	DE Die Farben der Abbildungen dienen nur der Veranschaulichung. EN The colors are for illustrating purposes only. FR Les couleurs utilisées sont à titre indicatif seulement.	DIN	ISO	Menge quantity quantité
1	Linsenflanschschraube / Lens head screw	M6x35 8 Nm	7381SA2	7381SA2	1
2	Linsenflanschschraube / Lens head screw	M5x16	7381SA2	7381SA2	5
3	Schalter / Switch				1
4	Kabelsatz / Cable set				1
5	Halter rechte&linke Seite / bracket right-left side				2
6	Linsenflanschschraube / lens head screw	M5 x 20 4 Nm	7381SA2	7381SA2	2
7	Linsenflanschschraube / lens head screw	M5 x 8 4 Nm	7381SA2	7381SA2	2
8	U-Scheibe / Washer	M5	9021SA2	7093	2
9	Scheinwerfer vormontiert / headlight preassembly				2
10	Schraubensicherung / Thread locking fluid				1
11	Kabelbinder / zip tie				16

LEGENDE / Key / file Légende

Anbau Tipp
Fitting tip
Astuce de montage

Achtung
Attention
Attention

Vergrößerung
Magnification
Grossissement

Montagepaste
Fitting lubricant
Lubrifiant de montage

Schraube
Screw
Vis

Schraubensicherung
Thread locking fluid
Freinfillets

Drehmoment
Torque
Torque

Reiniger
Cleaner
Nettoyant

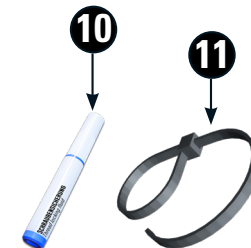

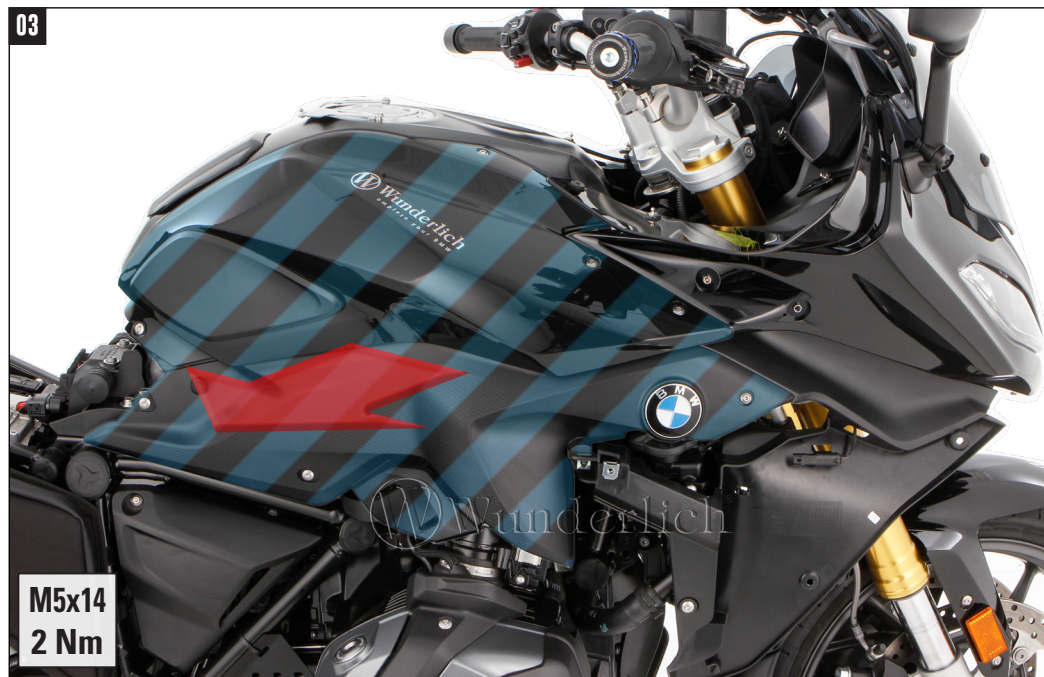

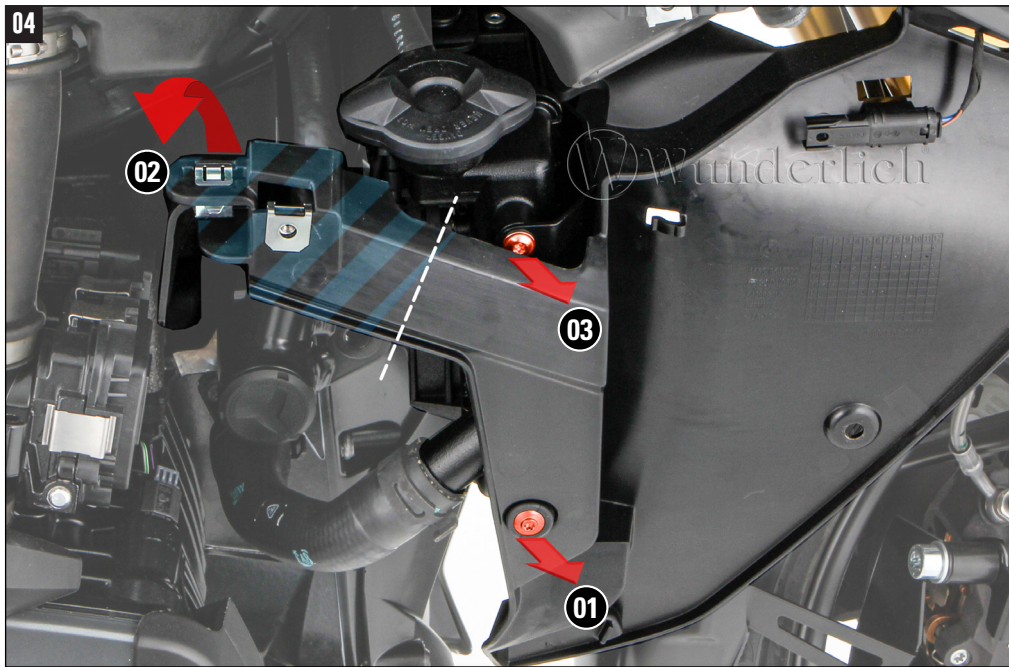

DE Der Reihe nach demontieren. Im 2 Schritt, Clip lösen. | **EN** Disassemble in order. In 2 steps, release the clip.
FR Démontez à tour de rôle. En 2 étapes, relâchez le clip.

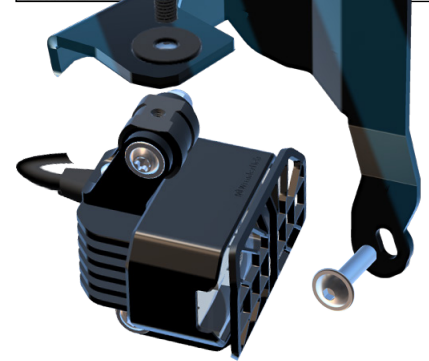
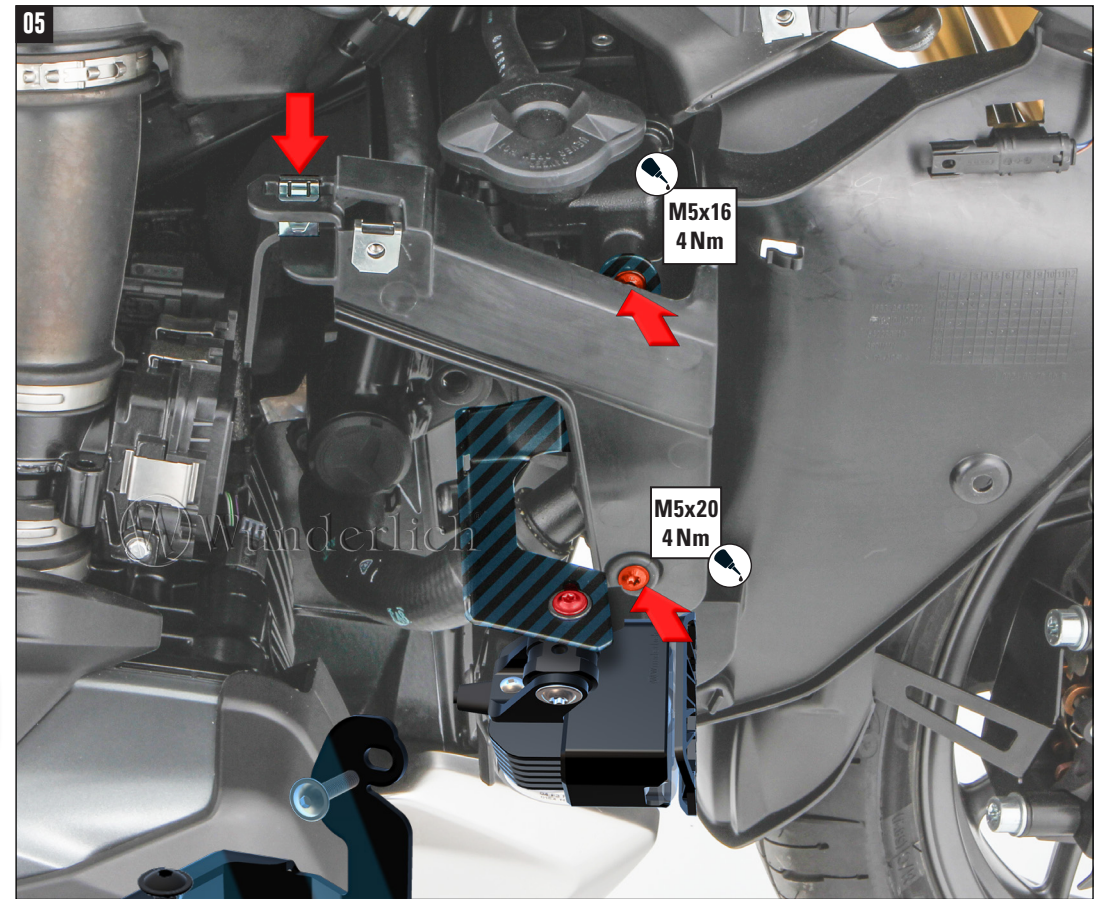
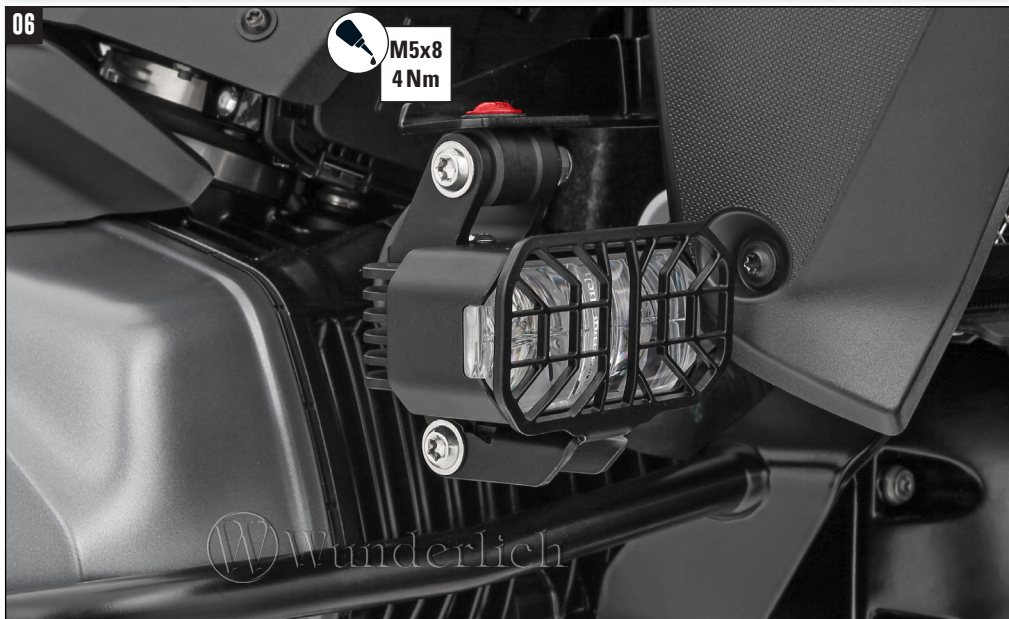

DE Der Reihe nach montieren und anschließen (Anschlußplan Seite 3). Verkleidung und Blinker in umgekehrter Reihenfolge montieren.
EN Install and connect in order (Connection diagram page 3). Assemble the fairing and indicators in the reverse order.
FR Installez et connectez-vous en séquence (Schéma de connexion page 3). Montez le carénage et les clignotants dans l'ordre inverse.

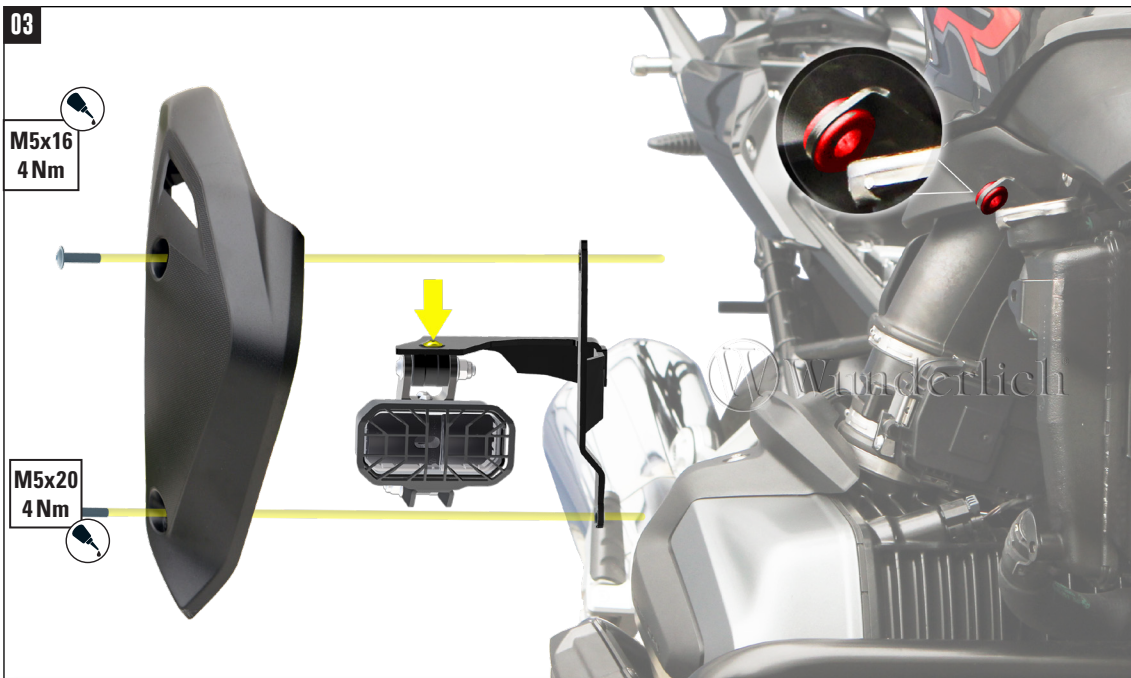

DE Microfooter anschließen (Anschlußplan Seite 3). Verkleidung in umgekehrter Reihenfolge montieren. Kühlerblende vor der Montage in die markierte Gummitülle einschieben.

EN Connect the auxiliary headlights (wiring diagram page 3). Fit the cover in reverse order. Before fitting, push the radiator cover into the marked rubber grommet.

FR Brancher les phares auxiliaires (schéma de câblage page 3). Montez le couvercle et procédez dans l'ordre inverse. Avant le montage, pousser le couvercle du radiateur dans l'œillet en caoutchouc marqué.